

JET

JPM-13CSX THICKNESSER

JPM-13CSX-M.....708524XM1~230V, 50Hz

JPM-13CSX-T.....708524XT3~400V, 50Hz

PARTS LIST

Walter Meier (Tool) AG
Tämperlistrasse 5
CH-8117 Fällanden
Switzerland
Phone +41 44 806 47 48
Fax +41 44 806 47 58
jetinfo.eu@waltermeier.com
www.jettools.com



P-708524XM/708524XT 2011-03

JPM-13CSX Table and Base Assembly

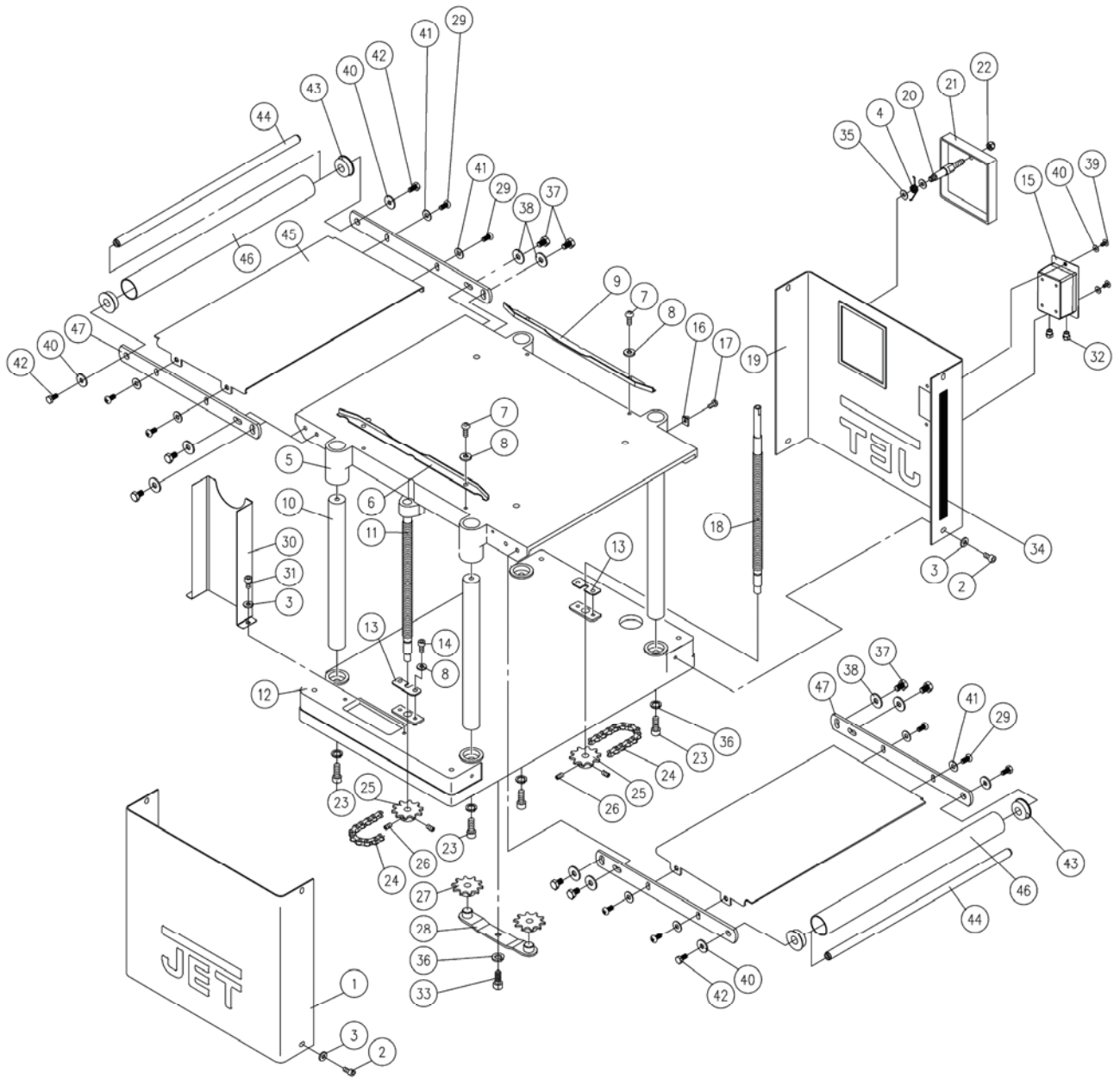

JPM-13CSX Table and Base Assembly

Index No.	Part No.	Description	Size	Qty.
1	MHA-B01EN	Cover (left)		1
2	TS-150301	Hex Socket Cap Screw	M6x8	8
3	TS-0680021	Flat Washer	1/4	8
4	JPM13-104	Spring		1
5	MHA-B02A	Middle Table		1
6	MGA-B29E	Guide (left)		1
7	TS-153403	Pan Head Machine Screw	M6x10	4
8	TS-155104	Lock Washer	M6	4
9	MGA-B15E	Guide (right)		1
10	MHA-B03EN	Column		4
11	MHA-B04EN	Leadscrew		1
12	MHA-B05EN	Base		1
13	MGA-B09	Anchor Plate		2
14	TS-150303	Hex Socket Cap Screw	M6x12	4
15	60A-119E	Magnetic Switch	KJD18 230V 1PH	1
	60A-119AE	Magnetic Switch	KJD18 400V 3PH	1
16	MHA-B20	Pointer		2
17	TS-153202	Pan Head Machine Screw	M4x8	2
18	MHA-B06EN	Leadscrew		1
19	MHA-B07EN	Cover (right)		1
20	MHA-B08EN	Stud		1
21	MHA-B09	Gear Box Cover		1
22	MHA-B19	Knob		1
23	TS-1504051	Hex Socket Cap Screw	M8x25	4
24	5GF-B07	Chain		1
25	PGE-B14	Sprocket		2
26	TS-152301	Set Screw	M6x6	4
27	PGE-B12	Sprocket		2
28	PGE-B10	Sprocket Idler		1
29	TS-1534042	Pan Head Screw		8
30	MHA-B10EN	Pulley Cover		1
31	TS-150302	Hex Socket Cap Screw	M6x10	2
32	JPM13-132	Strain Relief	PG11	2
33	TS-1504051	Hex Socket Cap Screw	M8x20	1
34	MGA-B04E	Scale (metric)		1
35	JPM13-135	Flat Washer		2
36	TS-155106	Lock Washer	M8	5
37	JPM13-137	Hex Head bolt	M8x12	8
38	TS-1550041	Flat Washer	M8	8
39	JPM13-139	Pan Head Screw	1/4"-20NCx1/2"	2
40	JPM13-140	Flat Washer	M6	6
41	JPM13-141	Flat Washer	6.4*16*1.0t	8
42	TS-1482021	Hex Cap Bolt	M6x12	4
43	PJ020804	Bushing		4
44	MHA-Y02A	Roller Shaft		2
45	JPM13-145	Extension Bed		2
46	MHA-Y02C	Roller		2
47	MHD-Y01AE	Roller Frame	M6	4
	JPM13-148	Extension Table Assembly (Include 43-47)		2

JPM-13CSX Cutterhead and Roller Assembly

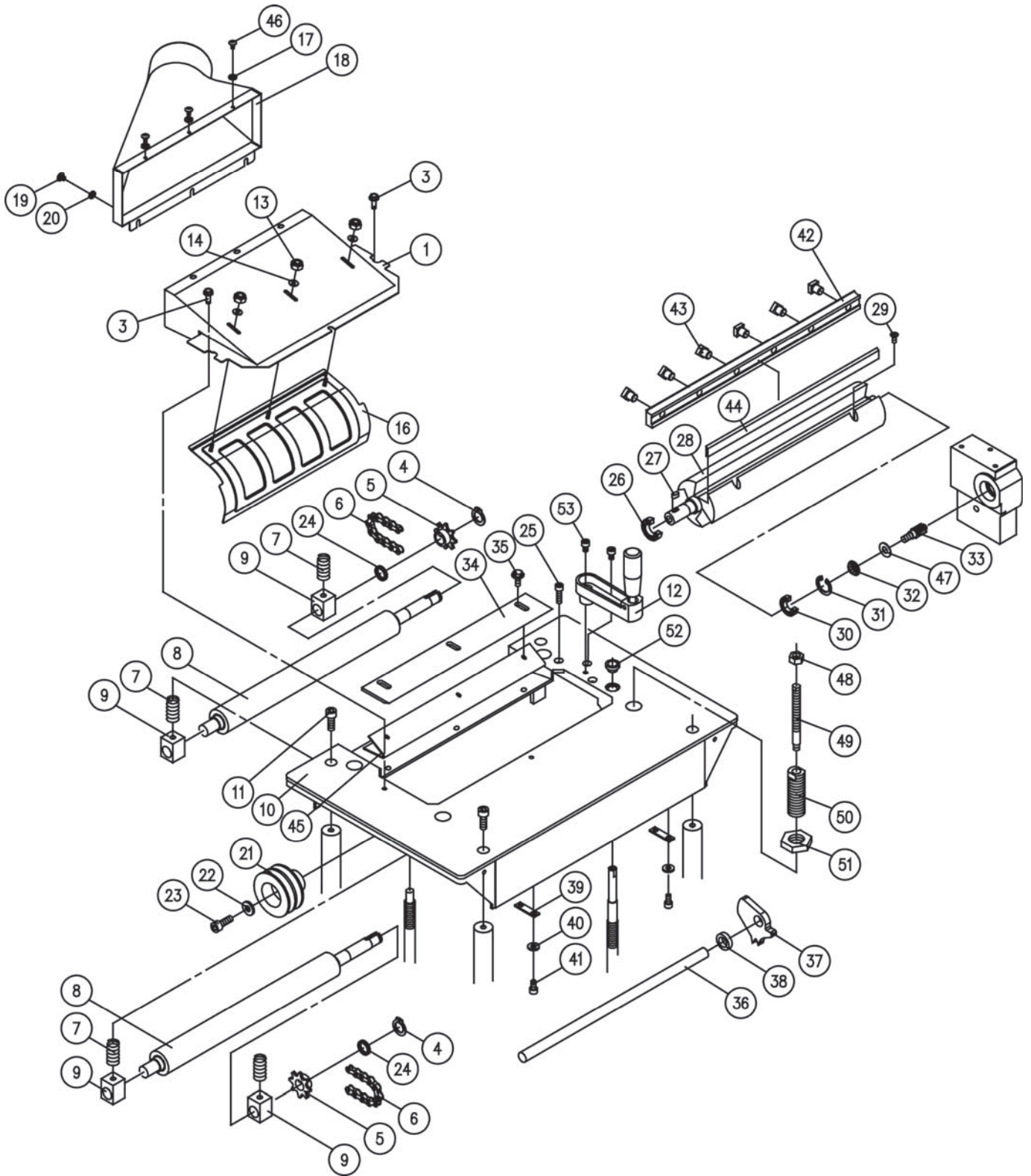

JPM-13CSX Cutterhead and Roller Assembly

Index No.	Part No.	Description	Size	Qty.
	MHA-C	Dust Hood Assembly CP		1
1	MHA-C01AE	Dust Hood		1
3	JPM13CSX-203	Hex Cap Screw w/Washer	M6x10	3
4	5FA-A10	C-Ring	STW15	2
5	PGA-C17	Sprocket		2
6	5GF-B08	Chain		2
7	PGA-C09	Spring		4
8	MHA-C02	Feed Roller		2
9	MGA-C09	Bushing		4
10	MHA-C03EN	Head Body		1
11	TS-150404	Hex Socket Cap Screw	M8x20	4
12	PGE-B19A	Handle Assembly		1
13	TS-1540021	Hex Nut	M4	3
14	TS-1550021	Flat Washer	M4	3
16	JPM13-216	Dust Hood		1
17	TS-1550031	Flat Washer	M5	3
18	MHA-Y01AWE	Dust Chute		1
19	HS040703	Screw	M6x20	3
20	TS-1550041	Flat Washer	M6	3
21	MHA-C05	Spindle Pulley		1
22	TS-0680021	Flat Washer	1/4	1
23	TS-1503051	Hex Socket Cap Screw	M6x20	1
24	MHA-C06	Spacer		2
25	TS-150304	Hex Socket Cap Screw	M6x16	2
26	BB-6203ZZ	Ball Bearing		1
27	5FK-C06	Key	5x5x15	1
28	MHA-C07E	Cutterhead		1
29	TS-151302	Flat Head Screw	M5x12	6
30	BB-6202ZZ	Ball Bearing		1
31	5BA-A28	C-Ring	RTW35	1
32	MHA-C08	Bushing		1
33	MHA-C09	Gear		1
34	MHA-C10E	Chip Deflector		1
35	5AK-E128	Screw	M6x12	3
36	MHA-C11E	Anti-Kickback Shaft		1
37	MGA-C30E	Anti-Kickback Finger		26
38	MGA-C34E	Anti-Kickback Collar		27
39	MGA-C31	Bracket		2
40	TS-155103	Lock Washer	M5	4
41	TS-150201	Hex Socket Cap Screw	M5x8	4
42	MHA-C12E	Lock Bar		3
43	JPM13-244	Hex Cap Bolt		18
44	MHA-C13	Knife		3
45	MHA-C22W	Plate		1
46	TS-1533031	Screw	M5x10	3
47	MHA-C20	Washer		1
48	TS-1540071	Hex Nut	M10x1.5	4
49	MGA-C07	Adjustment Screw		4
50	MGA-C05	Adjustment Screw		4
51	MGA-C06	Nut		4

JPM-13CSX Cutterhead and Roller Assembly

Index No.	Part No.	Description	Size	Qty.
52	PGE-B13.....	Bushing		1
53	TS-150302	Hex Socket Cap Screw *	M6x10.....	1

JPM-13CSX Gearbox Assembly

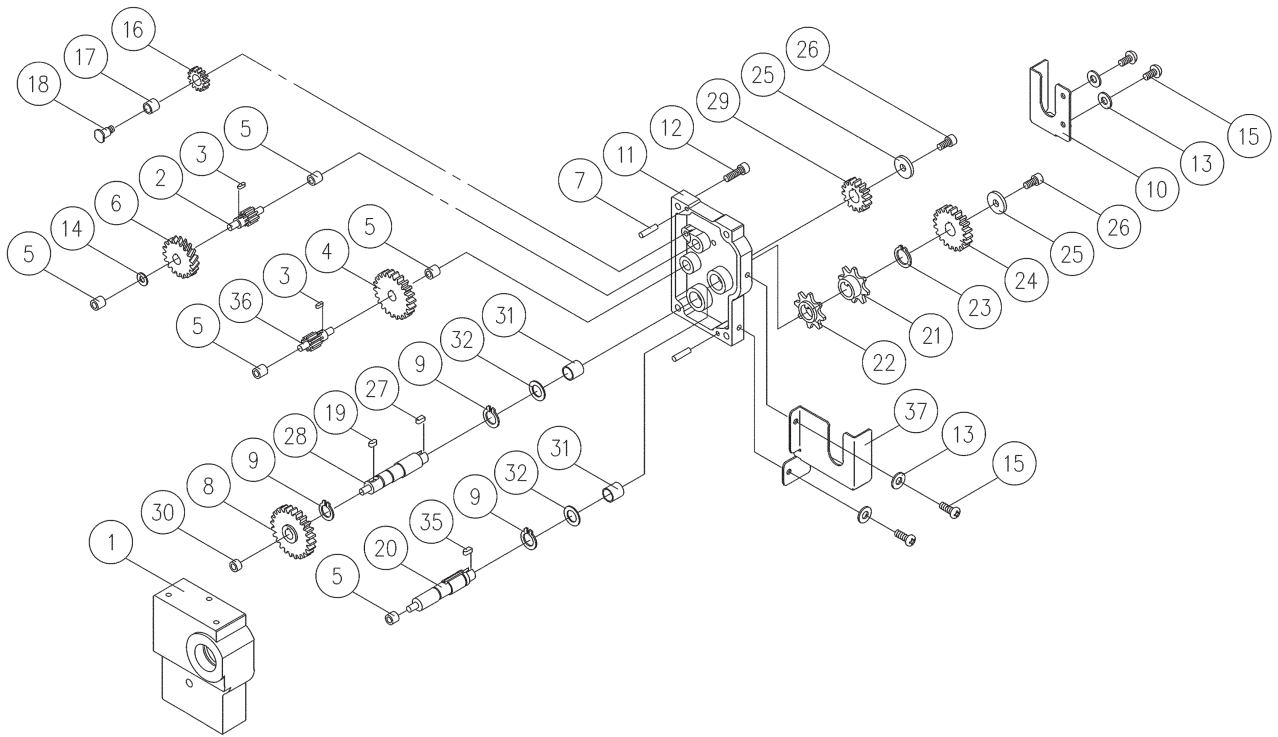

JPM-13CSX Gearbox Assembly

Index No.	Part No.	Description	Size	Qty.
	MA-GU	Gearbox Assembly(#'s 1-9, 11-12, 14, 16-32, 35-36)		1
1	MHA-G01U	Gearbox Body		2
2	MHA-G02	Gear Shaft	10T	1
3	FK-A03	Key	3x3x8	2
4	MHA-G03U	Gear	44T	1
5	PGA-M15	Bushing		5
6	MHA-G04U	Gear	43T	1
7	MGA-C28	Pin	4x16	2
8	MHA-G05U	Gear	47T	1
9	5FA-A07	C-Ring	STW12	3
10	JPM13-310	Chain Cover (Left)		1
11	MHA-G06E	Gear Box Cover		1
12	TS-150305	Hex Socket Cap Screw	M6x20	4
13	TS-1550041	Flat Washer	M6	4
14	TS-0680021	Flat Washer	1/4	1
15	JPM13-315	Pan Head Screw	M6x8	4
16	MHA-G08U	Gear	22T	1
17	PGA-M12	Bushing		1
18	MHA-G09	Stud Bolt	M6x1.0	1
19	MHA-G18	Key	5x5x9	1
20	MHA-G10N	Shaft		1
21	PGA-C17	Sprocket		1
22	MGA-C32	Sprocket		1
23	5FA-A10	C-Ring	STW15	1
24	MHA-G11U	Gear	40T	1
25	5EB-A08	Washer		1
26	TS-150303	Hex Socket Cap Screw		2
27	5FK-B02	Key	4x4x7	2
28	MHA-G12U	Shaft		1
29	MHA-G13U	Gear	29T	1
30	MHA-G14U	Bushing		1
31	MHA-G15N	Bushing		2
32	MHA-G16	Washer		2
35	5FK-B05	Key	4x4x12	3
36	MHA-G19	Gear Shaft	10T	3
37	JPM13-337	Chain Cover (Right)		1

JPM-13CSX Stand and Motor Assembly

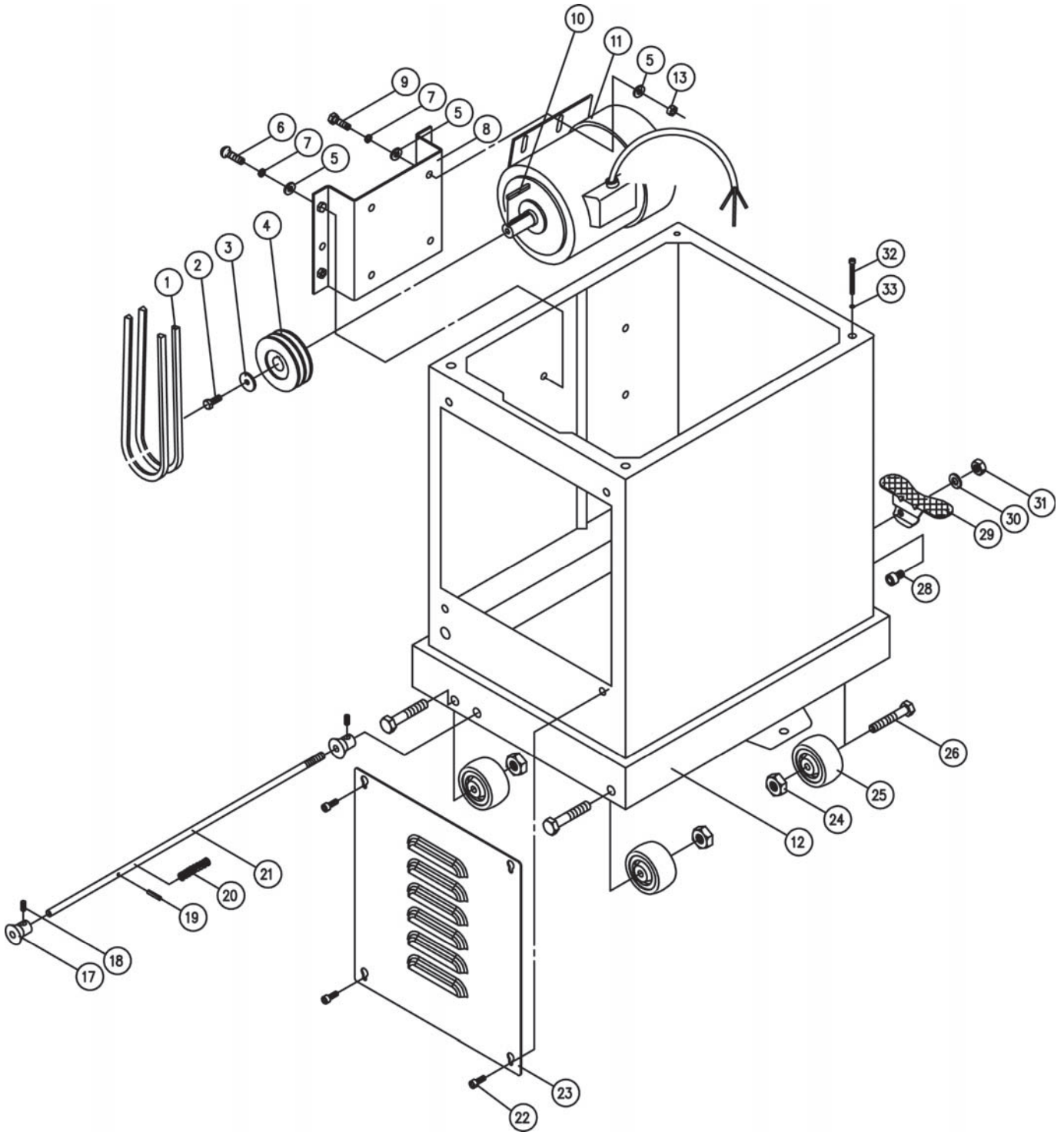

JPM-13CSX Satnd and Motor Assembly

Index No.	Part No.	Description	Size	Qty.
1	VB-M45E	V-Belt		2
2	TS-0051011	Hex Cap Bolt	5/16-18NCx1/2	1
3	PJA-C03	Washer		1
4	MHA-S01E	Motor Pulley		1
5	TS-1550061	Flat Washer	M8	12
6	TS-2288202	Round Cap Hex Socket Slot Screw	M8x1.25x20	4
7	TS-1551061	Lock Washer		8
8	MHD-S02	Motor Bracket		1
9	TS-1490031	Hex Cap Bolt	M8x1.25x20	4
10	5FK-C13A	Key	5x5x30	1
11	MHA-S02AWEN	Motor	1-1/2HP 230V 1PH	1
	MHA-S02AWA	Motor	2HP 400V 3PH	1
12	MHD-S01	Stand		1
13	TS-1540061	Hex Nut	M8x1.25	4
14	JPM13-414	Braking Label (not shown)		1
15	JPM13-415	Motor Label (not shown)		1
16	JPM13-416	JET Strip (not shown)		1
17	PJN-S04	Eccentric Cam		2
18	TS-1523011	Set Screw	M6x6	2
19	HG010911	Spring Pin	4x20	1
20	PG010033	Spring		1
21	MHD-S03	Shaft		1
22	JPM13CS-422	Socket Head Cap Screw	M6x14	4
23	PJ100001	Door		1
24	TS-0561031	Lock Nut	3/8-16NC	4
25	PJE-S05	Wheel		4
26	5CA-H16B	Hex Cap Bolt	3/8-16NCx2-1/2	4
27	PG-M02	JET Label (not shown)		1
28	TS-1503031	Hex Socket Cap Screw	M6x12	1
29	PJN-S02	Foot Brake		1
30	TS-1550071	Washer	M10	1
31	TS-2342101	Lock Nut	M10	1
32	JPM13CS-432	Socket Head Cap Screw	M6x65	4
33	TS-1550041	Flat Washer	M6	4

JPM-13CSX-M..... 708524XM1~230V, 50Hz

	colour of strands	Litzenfarben	couleur des cordons
BK	black	schwarz	noir
WH	white	weiß	blanc
BU	blue	blau	bleu
YE	yellow	gelb	jaune
RD	red	rot	rouge
BN	brown	braun	brun
GY	grey	grau	gris
GNYE	green-yellow	grün-gelb	vert-jaune
OG	orange	orange	orange
VT	violet	violett	violet

	meaning of symbol	Bedeutung der Zeichen	interprétation
M	motor	Motor	moteur
S	switch	Schalter	interrupteur
C	condenser	Kondensator	condensateur
E	electronic unit	Elektronik Einheit	unité électronique
F	fuse	Sicherung	fusible
RS	reversing switch	Drehrichtungsschalter	commu. droite/gauche
CS	centrifugal switch	Fliehkraftschalter	déclencheur centrifuge
OL	overload cut-off	Überlastschuttschalter	déclencheur surcharge
LS	limit switch	Positionsschalter	micro

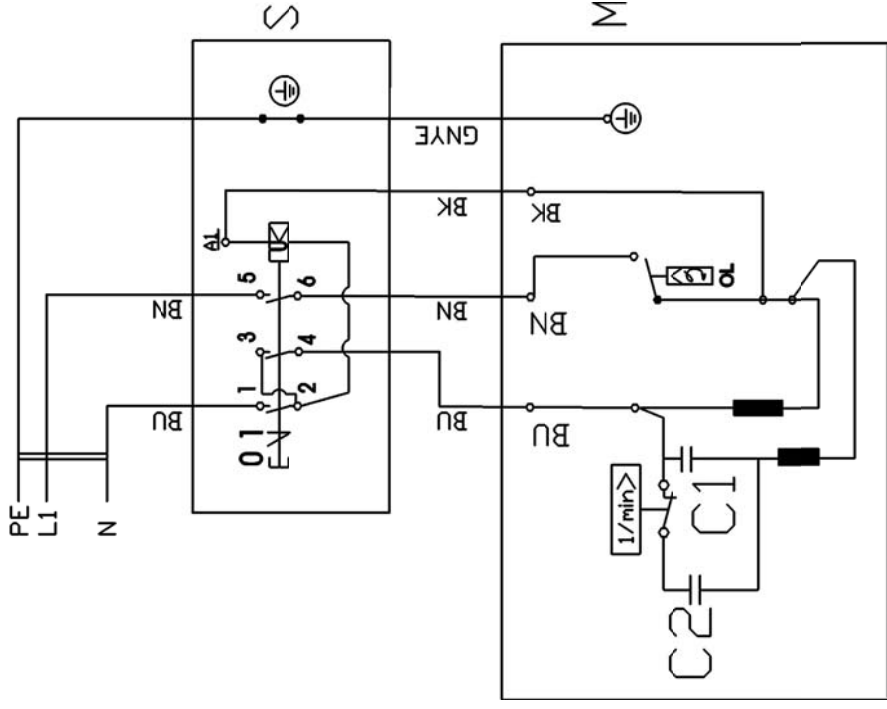

JPM-13CSX-T..... 708524XT3~400V, 50Hz

colour of strands	Litzenfarben	couleur des cordons
BK	schwarz	noir
WH	weiß	blanc
BU	blau	bleu
YE	gelb	jaune
RD	rot	rouge
BN	braun	brun
GY	grau	gris
GNYE	grün-gelb	vert-jaune
OG	orange	orange
VT	violett	violet

meaning of symbol	Bedeutung der Zeichen	interprétation
M	Motor	moteur
S	Schalter	interrupteur
C	Kondensator	condensateur
E	Elektronik Einheit	unité électronique
F	Sicherung	fusible
RS	Drehrichtungsschalter	commu. droite/gauche
CS	Fliehkraftschalter	déclencheur centrifuge
OL	Überlastschutzschalter	déclencheur surcharge
LS	Positionsschalter	micro

